

INFLUENCE OF GEOMETRY OF THERMAL MANIKINS ON CONCENTRATION DISTRIBUTION AND PERSONAL EXPOSURE

Claus Topp^{1*}, Peter Hesselholt², Mikkel Roed Trier³, Peter V. Nielsen¹

¹Dept. of Building Technology and Structural Engineering, Aalborg University, Denmark and International Centre for Indoor Environment and Energy, Technical University of Denmark

²Administrative Building & Cultural Management, Carl Bro Group, Denmark

³Internationalt Patent-Bureau A/S, Denmark

ABSTRACT

A number of different thermal manikins have been applied in literature to experimentally study the indoor environment. These manikins differ in size, shape and level of geometric complexity ranging from simple box or cylinder shaped thermal manikins to humanlike breathing thermal manikins. None of the reported studies however, deals with the influence of geometry of the thermal manikin. This paper provides an experimental study on the influence of manikin geometry on concentration distribution and personal exposure of a thermal manikin located in a full-scale displacement ventilated room.

The results show no significant influence of manikin geometry on personal exposure whereas the convective flow around the manikins and the concentration distribution at some distance showed to be different.

INDEX TERMS

Displacement ventilation, thermal manikin, air movement, personal exposure

INTRODUCTION

In indoor environmental engineering and research occupants are often accounted for by person simulators. In experimental work these simulators can be categorised as either *thermal manikins* (heat source and obstacle) affecting the room airflow pattern and temperature distribution or so-called *breathing thermal manikins* that in addition can be used as a tool for assessment of thermal comfort, indoor air quality and personal exposure.

A number of different thermal manikins have been applied in literature for studies of airflow, thermal comfort and personal exposure around the human body (Bjørn and Nielsen, 2002; Brohus and Nielsen, 1996; Xing, Hatton and Awbi, 2001; Chang and Gonzalez, 1993; Myers, Hosni and Jones, 1998; Lewis et al., 1969).

By means of Computational Fluid Dynamics Topp, Nielsen and Sørensen (2002) and Topp (2002) investigated the influence of geometry of computer simulated persons on air distribution, convective heat transfer, concentration distribution and personal exposure. The results showed that a simple geometry is sufficient when global flow is considered while a more detailed geometry should be used to assess thermal and atmospheric comfort.

Little effort however has yet been put into experiments on the influence of manikin geometry. It is straightforward to believe that the more humanlike geometry provides the better results but so far there is a lack of information on how much better the results would be.

* Contact author email: ct@civil.auc.dk

The objective of the present study is to investigate the influence of manikin geometry on concentration distribution and personal exposure of a thermal manikin in a displacement ventilated room. In another study Topp et al. (2003) studies the influence of manikin geometry in a mixing ventilated surroundings.

METHODS

A series of full-scale experiments were performed with four highly thermal different manikins as shown in Figure 1.

Both thermal manikin 1 and 2 (TM1 and TM2) is a simple rectangular shaped geometry of a seated person based on a standing Computer Simulated Person proposed by Brohus (1997). TM1 has “no legs” that is air is not allowed to pass between the legs, while TM2 has a space between the legs. TM3 and TM4 are breathing thermal manikins with a more complex and humanlike geometry. The manikins are identical with those applied in Topp et al. (2003).

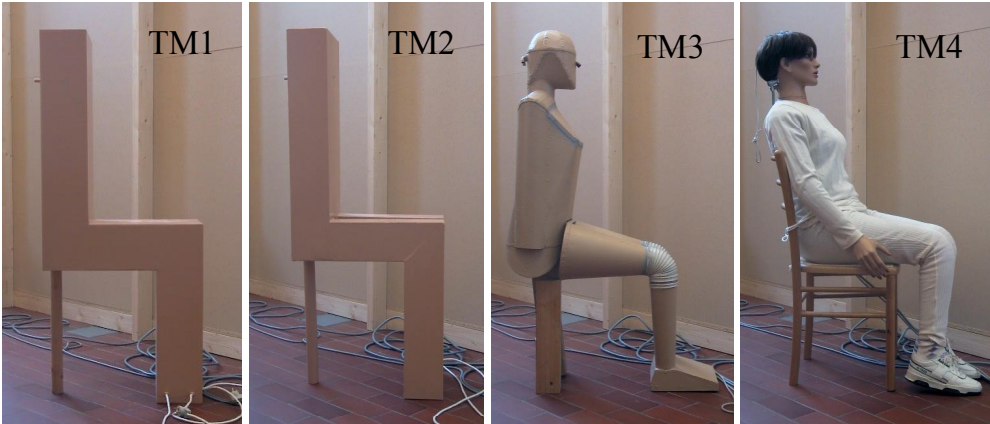

Figure 1. The investigated thermal manikins.

In the experiments the manikins are located in a mixing ventilated full-scale test room, see Figure 2. The manikins are seated facing the inlet diffuser and the two exhaust openings are located at the top of the same end wall. An additional heat source is placed behind the manikin to establish the desired stratification height. The manikin, heat source and inlet diffuser are centered on the x-axis.

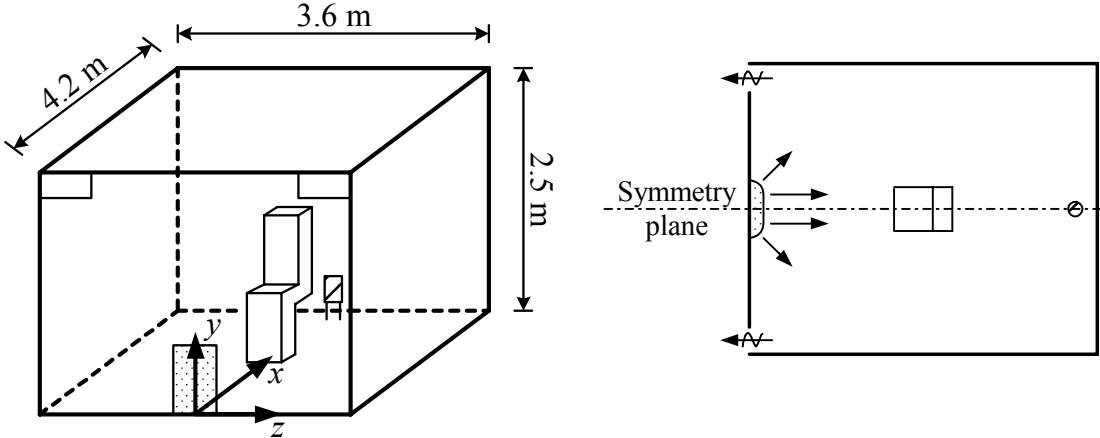

Figure 2. Outline and setup of the full-scale test room.

Tracer gas was added to the room from a pollutant source above the additional heat source to study concentration distribution and personal exposure. The concentration of CO₂ was then

measured at a number of points in the room. In addition, horizontal velocity profiles were measured at the mouth and the center of the torso with a Laser-Doppler anemometer.

To obtain a stratification height of 0.9 m, which is below the inhalation zone, the experiments were performed under the following conditions

- Flow rate of 110 m³/h corresponding to an air change rate of 2.9 h⁻¹
- Inlet temperature of 17°C
- Heat output from manikin of 79.8 W and 141 W from the additional heat source

RESULTS

The local airflow around the manikins is evaluated from horizontal velocity profiles at the mouth and the center of the torso. These are relevant in order to understand the personal exposure.

In Figure 3 the velocity profiles at the center of the torso are shown. The maximum velocity close to the body is significantly lower for TM1 as the manikin does not allow air to flow between the legs but instead forces flow around the legs. TM3 also experiences lower velocities close to the body. This might be caused by the geometry of the torso that is slightly bend forward compared to TM2 and TM4.

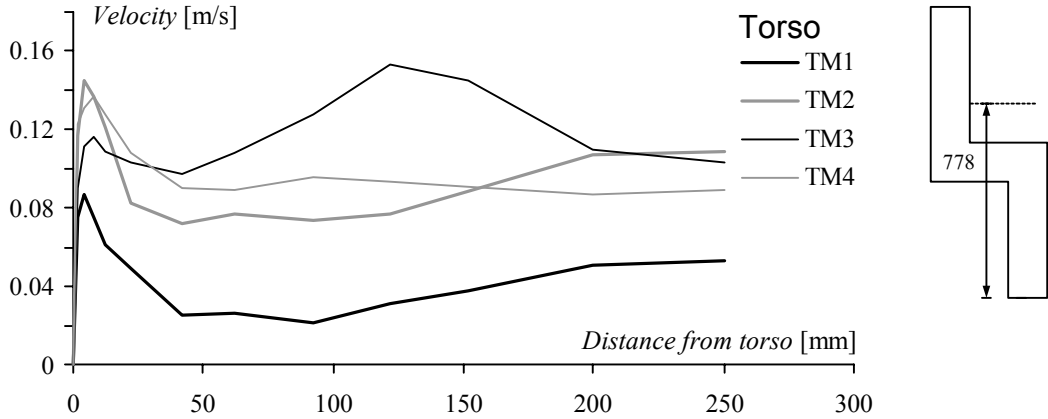

Figure 3. Velocity profiles at the center of the torso.

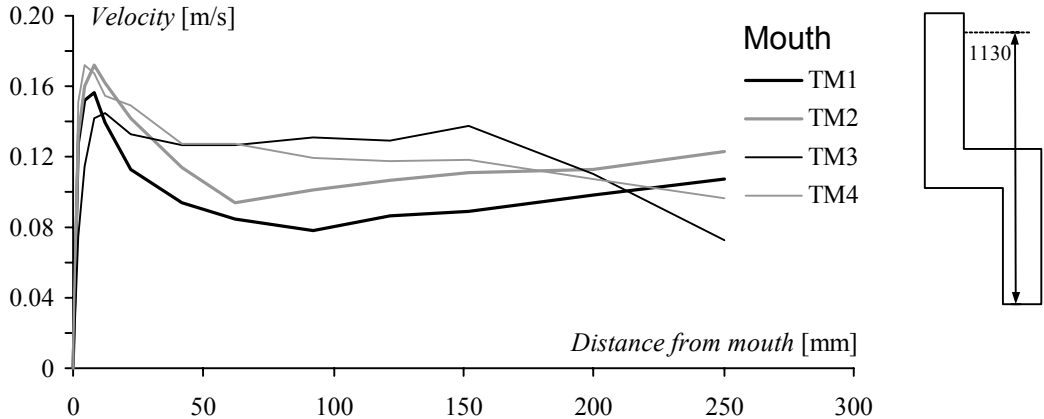

Figure 4. Velocity profiles at the mouth.

At the mouth the profiles are more similar as seen from Figure 4 although the velocity for TM1 is still lower. As the flow along the manikins is a convective flow the velocity level has increased compared to the torso.

To account for variation in source strength and inlet concentration of CO₂ (due to variation in outdoor CO₂ concentration) the concentrations are non-dimensionalised. The non-dimensional concentration, c^* , is given by

$$c^* = \frac{c - c_0}{c_R - c_0} \quad (1)$$

where c is the concentration in the actual point, c_0 is the concentration in the inlet and c_R is the concentration in the exhaust.

The non-dimensional concentrations are shown in Table 1 and the location of the measurement points are illustrated in Figure 5

Table 1. Dimensionless concentrations.

Point	$c^* [-]$ TM1	$c^* [-]$ TM2	$c^* [-]$ TM3	$c^* [-]$ TM4
1	0	0	0	0
2	1	1	1	1
3	0.53	0.51	0.84	0.65
4	0.64	0.73	0.70	0.56
5	0.05	0.05	0.07	0.05
6	0.01	0.02	0.02	0.02
7	0.66	0.67	0.83	0.72
8	0.09	0.06	0.16	0.47
9	0.08	0.09	0.10	0.08

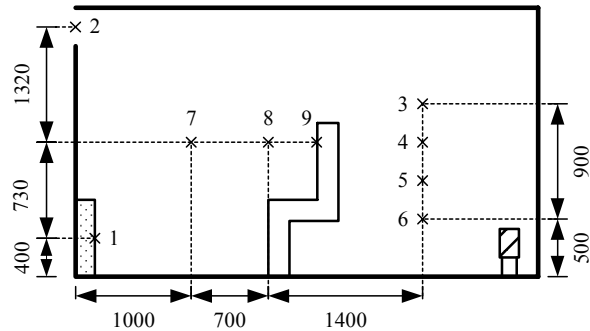

Figure 5. Location of measurement points for CO₂ concentration. All measures are in mm.

In general concentrations above the stratification height are higher than concentrations in the lower part of the room as expected for stratified surroundings. Exceptions are point 8 and 9 that are both influenced by the human boundary layer.

Point 9 is located at the mouth of the manikin and thus provides a measure of the personal exposure. Little influence of manikin geometry is observed as the concentrations are of corresponding values. The concentrations are low however, indicating a high efficiency of the human boundary layer. At point 8, which is located above the knees, concentrations are low for TM1 and TM2 whereas higher concentrations are observed for TM3 and in particular for TM4. This points to a vertical flow of clean air above the lap of TM1 and TM2 while the flow of clean air is attached to the body of TM4. This corresponds well with visual observations from smoke experiments.

Figure 6 shows the concentration gradients in the room. For all manikins the stratification height is between 800 mm and 1100 mm, which agrees well with the desired value of 900 mm. The gradients for TM3 and TM4 express the expected behaviour with higher concentrations above the stratification height but this is not the case for TM1 and TM2 where the concentrations drop.

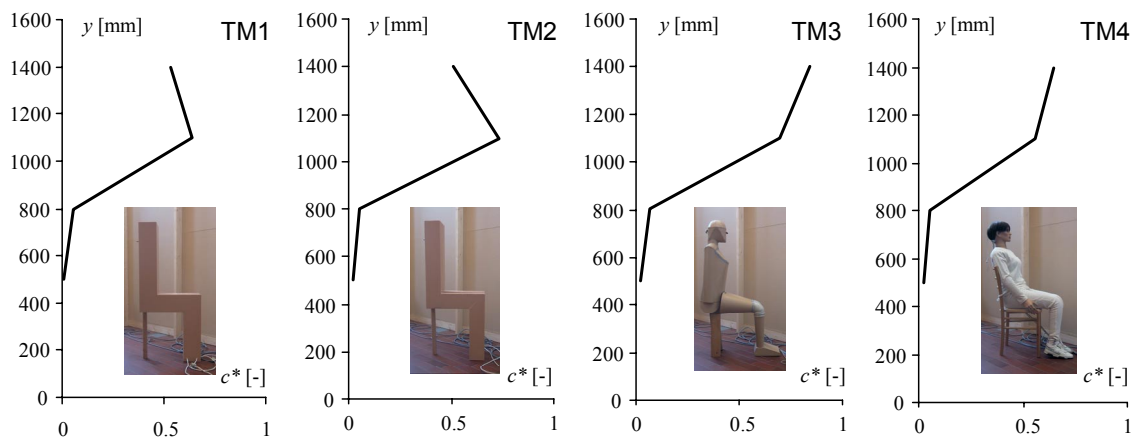

Figure 6. Concentration gradients (measurement points 3-6 in Figure 5).

DISCUSSION

A series of full-scale experiments were performed to investigate the influence of manikin geometry on concentration distribution and personal exposure for four different thermal manikins.

It was found that the horizontal velocity profiles at the center of the torso were highly different. The presence of a space between the legs showed important, as the velocity level for TM1 is significantly lower when the air is forced to flow around and not between the legs. At the mouth the profiles are of similar shape and magnitude and the velocity level is increased compared to the torso.

No significant difference in personal exposure was observed, as the concentrations at the mouth were almost identical. Above the knees, in the height of inhalation, different concentrations were found. For TM1 and TM2 the concentrations were low due to a clean upward flow from the lap whereas higher concentrations were found for TM3 and in particular TM4 were the flow was attached to the body of the manikins.

CONCLUSIONS AND IMPLICATIONS

When interested in personal exposure the present study shows no significant difference between a simple rectangular shaped geometry and a more complex and humanlike geometry. This is beneficial as simple manikins are less expensive and often easier to operate. The concentration distributions showed to be different at some distance from the manikins due to different convective flows around the manikins.

It is the future objective to further extend the knowledge on influence of manikin geometry on airflow, personal exposure and contaminant distribution to assess tasks suitable for geometrically simple manikins and tasks where a more complex geometry is required, that is to provide guidelines for choice of manikin geometry based on problem characteristics.

ACKNOWLEDGEMENTS

This research was funded by the Danish Technical Research Council (STVF) as a part of the International Centre for Indoor Environment and Energy at the Technical University of Denmark.

REFERENCES

Bjørn, E. and Nielsen, P. V. 2002. Dispersal of exhaled air and personal exposure in displacement ventilated rooms. *Indoor Air*, Vol. 12, p. 147-164.

- Brohus, H. 1997. Personal exposure to contaminant sources in ventilated rooms. PhD Thesis, Aalborg University, Denmark, ISSN 0902-7953 R9741.
- Brohus, H. and Nielsen, P.V. 1996. Personal exposure in displacement ventilated rooms. *Indoor Air*, Vol. 6 (3), p. 157-167.
- Chang, S. K. W and Gonzalez, R. R. 1993. Air velocity profiles around the human body. *ASHRAE Transactions*, 99 (1), p. 450-458.
- Lewis, H. E., Foster, A. R., Mullan, B. J., Cox, R. N. and Clark, R. P. 1969. Aerodynamics of the human minienvironment. *The Lancet*, Saturday June 28 1969.
- Myers, J. B., Hosni, M. H. and Jones, B. W. 1998. Interaction of air motion with the human body. *ASHRAE Transactions*, 104 (1B), p. 863-882.
- Topp, C., Hesselholt, P., Trier, M. R. and Nielsen, P. V. 2003. Influence of Geometry of Thermal Manikins on Room Airflow. *Proceedings of Healthy Buildings 2003*, Singapore.
- Topp, C. 2002. Influence of Geometry of a Computer Simulated Person on Contaminant Distribution and Personal Exposure. *Proceedings of ROOMVENT 2002, Eight International Conference on Air Distribution in Rooms*, Copenhagen Denmark.
- Topp, C., Nielsen, P. V. and Sørensen, D. N. 2002. Application of Computer Simulated Persons in Indoor Environmental Modeling. *ASHRAE Transactions*, 108 (2), p. 1084-1089.
- Xing, H., Hatton, A. and Awbi, H. B. 2001. A study of the air quality in the breathing zone in a room with displacement ventilation. *Building and Environment* 36, p. 809-820.